

## Foil suction cup

GO 30 - GO 100

# FEZER

Simply move more.

### Description

Special suction cup for handling of foils or foil-wrapped parts. The suction have a special pad which prevents that the foils are completely sucked in. The cup is clipped on a tube socket or connection nipple. To increase the safety the cups can be additionally fastened by hose clamps or cable ties. They can be easily exchanged when worn out. Please order the connection nipple separately.

### Application

- handling of foil material
- handling of foil-wrapped parts



FS-GO 30 ... FS-GO 100

### Article numbers

Type	NBR-G	SI-T	Connection nipple	
			Type	Art.-Nr:
FS-GO 30	1.11.1.0290	1.11.1.0468	ANF-10-1/4	1.31.1.0026
FS-GO 40	1.11.1.0470	1.11.1.0471	ANF-10-1/4	1.31.1.0026
FS-GO 50	1.11.1.0473	1.11.1.0474	ANF-10-1/4	1.31.1.0026
FS-GO 70	1.11.1.0476	1.11.1.0477	ANF-16-1/4	1.31.1.0031
FS-GO 100	1.11.1.0479	1.11.1.0480	ANF-16-1/4	1.31.1.0031

### Technical details

Type	Holding force* (N)	Volume** (l)	Weight (kg)
FS-GO 30	32	0,008	0,004
FS-GO 40	47	0,015	0,006
FS-GO 50	65	0,023	0,009
FS-GO 70	94	0,050	0,015
FS-GO 100	152	0,092	0,020

\* Specifications at 60 % vacuum w/o safety factor, on smooth, dry surfaces

\*\* Volume with suction pad not engaged and unloaded

## Foil suction cup

GO 30 - GO 100

# FEZER

Simply move more.

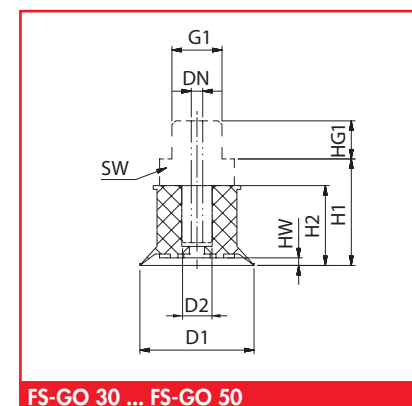

FS-GO 30 ... FS-GO 50

### Dimensions

Type	D1	D2	DN	HW	H1	H2	HG1	G	SW
FS-GO 30	30	8	5	2	36	21	10	G1/4	19
FS-GO 40	40	8	5	2	36	21	10	G1/4	19
FS-GO 50	50	10	5	5	39	24	10	G1/4	19
FS-GO 70	70	16	5	10	49	34	10	G1/4	19
FS-GO 100	80	16	5	10	58	43	10	G1/4	19

### Suitable connection elements

Type	Suction pad retainer		Holding bracket	Holders		Suspension bolt
	SAS	SAK		Bushing	Holding joint	
FS-GO 30 ... FS-GO 100	SAS-M12x1-1/4	---	HSW-M12x1-1/4	HSB-1/4-1/4	HSG-M12x1-1/4	FS ... -M12x1