

Flat suction plate, round

FSRL 120 - FSRL 600 with grooved pad

FEZER
Simply move more.

Description

Robust and extremely resistant flat suction pad with grooved pad, long lips and additional inner sealing. The gasket is pulled over the body and can be easily exchanged when worn out. The suction pads are available with central (Z) or lateral (S) vacuum feed. Please order the connection screw separately.

Application

- flat, sensitive workpieces
- smooth to slightly rough surfaces
- suitable for short suction resp. cycle times
- imprint-free design in viton

Dimensions

Type	Suction pad			Replacement gasket			Connection screw	
	NBR-G	SI-T	VI-S	NBR-G	SI-T	VI-S	Type	Art.-Nr:
FSRL 120 Z	1.11.1.0248	1.11.1.0382	1.11.1.0530	2.11.2.0089	2.11.2.0102	2.11.2.0104	ASB-M16-20	1.31.2.0084
FSRL 120 S	1.11.1.0293	1.11.1.0384	1.11.1.0532	2.11.2.0114	2.11.2.0126	2.11.2.0174	AS-M16-22	1.31.2.0035
FSRL 170 Z	1.11.1.0250	1.11.1.0385	1.11.1.0526	2.11.2.0090	2.11.2.0119	2.11.2.0170	ASB-M16-20	1.31.2.0084
FSRL 170 S	1.11.1.0343	1.11.1.0356	1.11.1.0533	2.11.2.0127	2.11.2.0128	2.11.2.0175	AS-M16-22	1.31.2.0035
FSRL 230 Z	1.11.1.0251	1.11.1.0387	1.11.1.0525	2.11.2.0091	2.11.2.0120	2.11.2.0122	ASB-M16-20	1.31.2.0084
FSRL 230 S	1.11.1.0350	1.11.1.0388	1.11.1.0534	2.11.2.0130	2.11.2.0131	2.11.2.0176	AS-M16-22	1.31.2.0035
FSRL 290 Z	1.11.1.0271	1.11.1.0389	1.11.1.0531	2.11.2.0094	2.11.2.0121	2.11.2.0173	ASB-M16-20	1.31.2.0084
FSRL 290 S	1.11.1.0383	1.11.1.0390	1.11.1.0535	2.11.2.0132	2.11.2.0133	2.11.2.0177	AS-M16-22	1.31.2.0035
FSRL 340 S	1.11.1.0179	1.11.1.0142	1.11.1.0541	vulcanized			AS-M24x1,5-28	1.31.2.0069
FSRL 400 S	1.11.1.0180	1.11.1.0144	1.11.1.0542	vulcanized			AS-M24x1,5-28	1.31.2.0069
FSRL 500 S	1.11.1.0181	1.11.1.0146	1.11.1.0543	vulcanized			AS-M24x1,5-28	1.31.2.0069
FSRL 600 S	1.11.1.0182	1.11.1.0148	1.11.1.0544	vulcanized			AS-M24x1,5-28	1.31.2.0069

Z = central vacuum feed
S = lateral Vacuum feed

Technical details

Type	Holding force* (N)	Volume** (l)	Weight (kg)
FSRL 120 Z / S	550	0,06	0,33
FSRL 170 Z / S	1.150	0,12	0,55
FSRL 230 Z / S	2.100	0,20	1,00
FSRL 290 Z / S	3.040	0,78	1,95
FSRL 340 S	3.640	1,30	2,50
FSRL 400 S	4.000	2,60	6,00
FSRL 500 S	7.100	4,30	11,80
FSRL 600 S	9.500	6,80	18,40

* Specifications at 60 % vacuum w/o safety factor, on smooth, dry surfaces
** Volume with suction pad not engaged and unloaded



FSRL 120 ... FERL 600

Flat suction plate, round

FSRL 120 - FSRL 600 with grooved pad

FEZER
Simply move more.

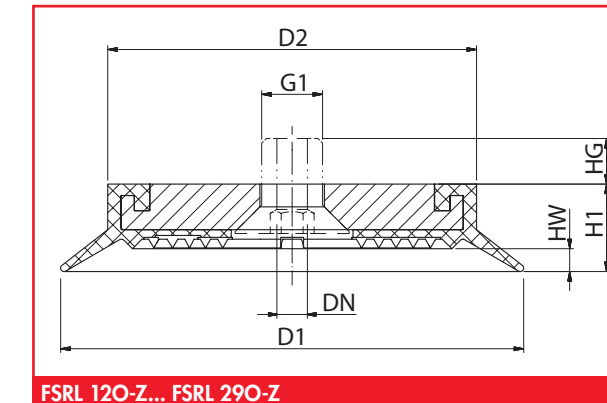

FSRL 120-Z... FSRL 290-Z

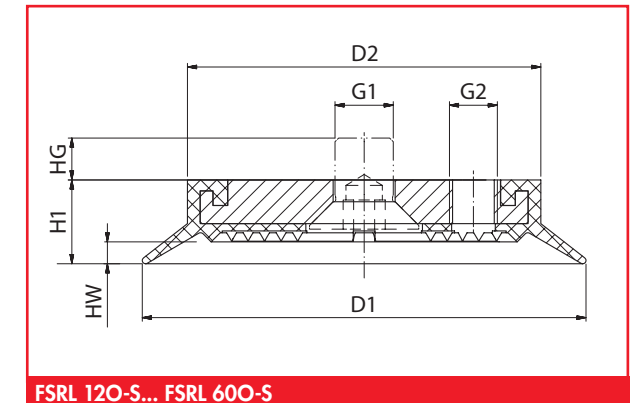

FSRL 120-S... FSRL 600-S

Dimensions

Type	D1	D2	DN	HW	H1	HG	G1	G2
FSRL 120 Z	120	97	8	6	23	8,5	M16	---
FSRL 120 S	120	97	---	6	23	8,5	M16	G1/4
FSRL 170 Z	170	147	8	6	23	8,5	M16	---
FSRL 170 S	170	147	---	6	23	8,5	M16	G1/4
FSRL 230 Z	220	197	8	6	23	13	M16	---
FSRL 230 S	220	197	---	6	23	13	M16	G1/2
FSRL 290 Z	290	267	8	6	23	13	M16	---
FSRL 290 S	290	267	---	6	23	13	M16	G1/2
FSRL 340 S	340	300	---	14	32	22	M20	G1/2
FSRL 400 S	400	300	---	17	46	22	M20	G1/2
FSRL 500 S	500	400	---	17	46	22	M24	G3/4
FSRL 600 S	600	500	---	17	46	22	M24	G3/4

Suitable connection elements

Type	Suction pad retainers		Suspension bolt
	SAS	SAK	
FSRL 120 ... FSRL 170	SAS-M16x1,5-M16	SAK-M16x1,5-M16	FS ... -M16x1,5
FSRL 230 ... FSRL 290	SAS-M20x1,5-M16	SAK-M20x1,5-M16	FS ... -M20x1,5
FSRL 340 ... FSRL 400	SAS-M20x1,5-M24x1,5	SAK-M20x1,5-M24x1,5	FS ... -M20x1,5*
FSRL 500 ... FSRL 600	SAS-M30x1,5-M24x1,5	SAK-M30x1,5-M24x1,5	FS ... -M30x1,5*

* Stössel ohne integrierte Vacuum feed